

Accessori a richiesta / By request



Impianto di raffreddamento aria/olio (montato)
Oil cooler (mounted)



Compensatore idro-pneumatico sul cilindro alzata
Hydropneumatic compensator



Comandi elettro-idraulici a portata costante con joystick
Electro-Hydraulic controls with joystick



Comandi elettro-idraulici a portata costante con mini-manipolatori
Electro-Hydraulic controls with mini-manipulators

Decespugliatore Professionale BSRProf

Attrezzi terminali intercambiabili all'apparato trinciante Terminal Implements in the place of flail hedge mower



| Modello Model | BF150 | BF170 |
|-----------------------------------------|-------|-------|
| Larghezza cm Working width cm | 150 | 170 |
| Peso Kg. Weight Kg. | 110 | 135 |
| Motore idraulico cc Hydraulic engine | 52-63 | 52-63 |
| N. Lame Blades Nr. | 2 | 2 |

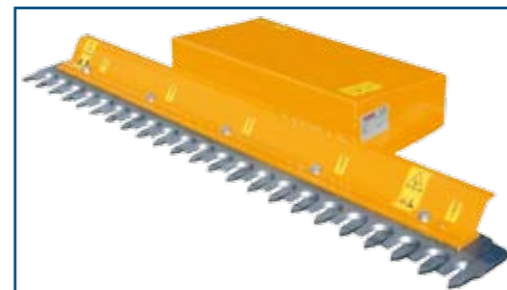

| Modello Model | TR130 | TR200 |
|-------------------------------------------------|-------|-------|
| Larghezza cm Working width cm | 130 | 200 |
| Peso Kg. Weight Kg. | 180 | 230 |
| Diam.max taglio rami cm Max diam. Cutting cm | 8 | 8 |



| Modello Model | FF50 |
|-----------------------------------------|------|
| Larghezza cm Working width cm | 50 |
| Peso Kg. Weight Kg. | 130 |
| Motore idraulico cc Hydraulic engine | 200 |



| Modello Model | AS29H |
|---------------------------------------|-------|
| Girante Diam.mm Impeller diam.mm | 290 |
| N. pale N.blades. | 7 |
| Portata aria mc/m Ejected air mc/m | 90 |



PROCOMAS

PROCOMAS srl

Via Vegri, 241 - 45036 Ficarolo (RO) - Italy - tel. +39 0425 708389 / 708458 - fax +39 0425 727253 - procomas@libero.it - www.procomas.it

Progettazione e Costruzione di Macchine
per la Manutenzione Professionale del Verde
Machines for Professional Green Maintenance

PROCOMAS



| Modello Model Model Modelo | Trinciatrice Idraulica Hydraulic Flail mower Hydraulische mulcher Trituradora hidráulica | Peso Trinciatrice Kg. Weight Flail Mower Kg. Gewicht Mulcher Kg. Peso Trituradora Kg. | Rotore Standard Standard Flails Standard Messer Norma cuchillos | Rotore a richiesta Flails by request Messer auf Anfrage Cuchillos en la solicitud |
|-------------------------------------|---------------------------------------------------------------------------------------------------|------------------------------------------------------------------------------------------------|--------------------------------------------------------------------------|--------------------------------------------------------------------------------------------|
| BSR P5 | F100 | 190 | F3 | (F1-F5-F8) |
| BSR P5 | F120 | 210 | F3 | (F1-F5-F8) |
| BSR P5 | F110 | 240 | F3 | (F1-F4-F5-F6-F8) |
| BSR P5 | F130 | 260 | F3 | (F1-F4-F5-F6-F8) |
| BSR P6 | F100 | 190 | F3 | (F1-F5-F8) |
| BSR P6 | F120 | 210 | F3 | (F1-F5-F8) |
| BSR P6 | F110 | 240 | F3 | (F1-F4-F5-F6-F8) |
| BSR P6 | F130 | 260 | F3 | (F1-F4-F5-F6-F8) |

IT

BSRProf

Decespugliatore Professionale

Progettato e costruito per poter superare più facilmente i guard-rails di nuova concezione sfruttando al massimo tutta la lunghezza del braccio; la nuova linea studiata lo rende piacevole e organico in tutto il suo volume.

Fornito di serie con:

- Trinciatrice idraulica con larghezza di lavoro cm 100 o 120, zappette a Y F3 con reversibilità albero porta zappe, protezioni ce, rullo regolabile in altezza.
- Impianto idraulico indipendente a doppio circuito con motore e pompa ad ingranaggi in ghisa ad elevate prestazioni.
- Moltiplicatore per pompe in bagno d'olio e presa di forza 540 giri/m'
- Tubi ad alta resistenza protetti da spirale
- Comandi a mezzo cavi flessibili
- Dispositivo per l'assorbimento di eventuali urti frontali
- Serbatoio olio con lt 150
- Tenditori e cardano
- Manuale ce con dichiarazione di conformità e tavolo ricambi.

GB

BSRProf

Professional Hydraulic hedge flail mower

Designed and built in order to more easily overcome the guard-rails of new concepts; is exploited throughout the length of arm, the new line makes it pleasant and staff throughout its volume.

Standard supplied with:

- Flail mower working width cm 100 or 120, Y flails F3 with reversible rotor, Ce protection, adjustable roller.
- Independent hydro plant, iron double pump with high performance.
- Gear box for PTO 540/rpm.
- Hydraulic's tube with PVC spiral protection.
- Cable controls.
- Hydraulic safety device.
- Oil tank with lt. 150
- Cardan shaft and tractor stabilizers.
- Manual CE with CE conformity declaration and spare parts list.

DEU

BSRProf

Hydraulische profi-schlegelmulcher mit ausleger

Entworfen und gebaut zu können leichter Überwindung der Barrieren mit der gesamten Länge de ausleger.

Kommt mit:

- Hydraulische mulcher Breite der Arbeit mit 100 oder 120 cm, rotor mit polyvalent Y-messern F3; protections CE, Roll verstellbare Höhe
- Hydr.mehrfachpumpen.
- Vorbereitet für zapfwelle mit 540 U/min.
- High-Stärke Rohre vor Spirale.
- Befehle durch flexible Kabel.
- Geräte für die Absorption eines frontalen.
- Öl-Tank mit LT 150.
- Kardanwelle.
- Ce-Handbuch mit Konformitätserklärung und Tabellen Ersatzteilen.

ESP

BSRProf

Decespugliatore profesionales

Diseñado y construido con el fin de superar más fácilmente las barreras utilizando toda la longitud del brazo; la nueva línea hace que sea agradable y personal en todo su volumen.

Viene con:

- Trituradora hidráulica de trabajo con 100 o 120 cm de ancho, cuchillas en "Y" F3, protecciones CE, rodillo regulable en altura.
- De instalaciones de fontanería de doble circuito, el motor y con bomba de engranajes de alto rendimiento.
- Multiplicador de bombas en un baño de aceite y 540 rpm PTO.
- De alta resistencia tubos protegidos de la espiral.
- Comandos por cables flexibles.
- Dispositivo para absorber cualquier choque frontal.
- Depósito de aceite lt 150.
- Cardan.
- Manual de declaración CE de conformidad con los cuadros y piezas de repuesto.

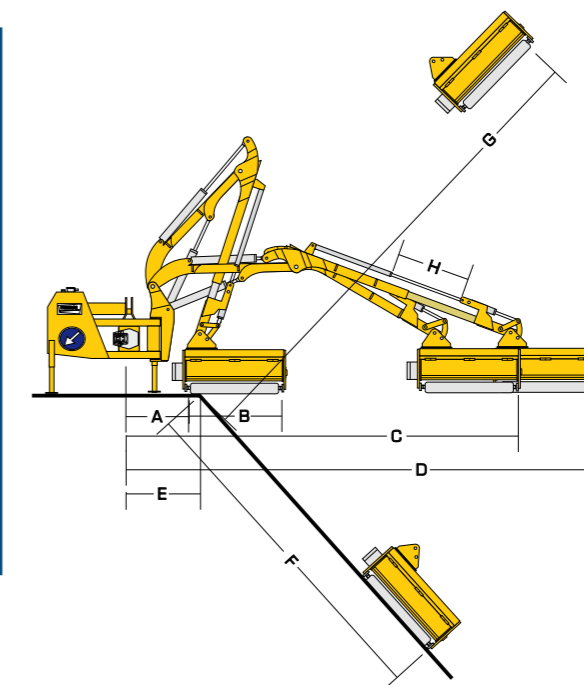

| Modello Model Model Modelo | A | B | C | D | E | F | G | H |
|-------------------------------------|------|------|------|------|------|------|------|-----|
| BSR P5 F100 | 0,90 | 1,00 | 4,88 | - | 1,20 | 2,50 | 4,50 | - |
| BSR P5 F120 | 0,90 | 1,20 | 5,08 | - | 1,20 | 2,70 | 4,70 | - |
| BSR P5 F110 | 0,90 | 1,00 | 4,88 | - | 1,20 | 2,50 | 4,50 | - |
| BSR P5 F130 | 0,90 | 1,20 | 5,08 | - | 1,20 | 2,70 | 4,70 | - |
| BSR P6 F100 | 0,90 | 1,00 | - | 5,55 | 1,20 | 3,30 | 5,17 | 0,8 |
| BSR P6 F120 | 0,90 | 1,20 | - | 5,75 | 1,20 | 3,50 | 5,37 | 0,8 |
| BSR P6 F110 | 0,90 | 1,00 | - | 5,55 | 1,20 | 3,30 | 5,17 | 0,8 |
| BSR P6 F130 | 0,90 | 1,20 | - | 5,75 | 1,20 | 3,50 | 5,37 | 0,8 |

| Modello Model Model Modelo | Telescopico Mt. Telescopic Mt. Teleskoplander Mt. Telescopicas Mt. | Peso Kg. Weight Kg. Gewicht Kg. Peso Kg. | Sbraccio Mt. Arm Mt. Arm Mt. Brazo Mt. | Trattrice / Tractor | | |
|-------------------------------------|-----------------------------------------------------------------------------|---------------------------------------------------|-------------------------------------------------|------------------------------------------------------------------------------------------------------------------------|---------------------------------------------------|---------------------------------|
| | | | | Min-Max Potenza Cv/Hp (KW) Min-Max Power Cv/Hp (KW) Min-Max Power Cv/Hp (KW) Mínimo - Máximo poder Cv/Hp (KW) | Peso Kg. Weight Kg. Gewicht Kg. Peso Kg. | Carareggiata mm Wheelbase mm |
| BSR P5 F100 | - | 850 | 4,88 | 70/80-(51,4-58,8) | 2500 | 1700 |
| BSR P5 F120 | - | 880 | 5,08 | 80/90-(58,8-66,1) | 2600 | 1700 |
| BSR P5 F110 | - | 900 | 4,88 | 70/80-(51,4-58,8) | 2700 | 1700 |
| BSR P5 F130 | - | 930 | 5,08 | 80/90-(58,8-66,1) | 2800 | 1700 |
| BSR P6 F100 | 0,8 | 950 | 5,55 | 80/90-(58,8-66,1) | 3000 | 1800 |
| BSR P6 F120 | 0,8 | 980 | 5,75 | 90/100-(66,1-73,5) | 3100 | 1800 |
| BSR P6 F110 | 0,8 | 960 | 5,55 | 90/100-(66,1-73,5) | 3200 | 1800 |
| BSR P6 F130 | 0,8 | 990 | 5,75 | 100(110)-(73,5-80,8) | 3300 | 1800 |

Rotori Standard



F3

Rotori a richiesta



F1



F5



F4-F8



F6

